

Kennlinien / Characteristics

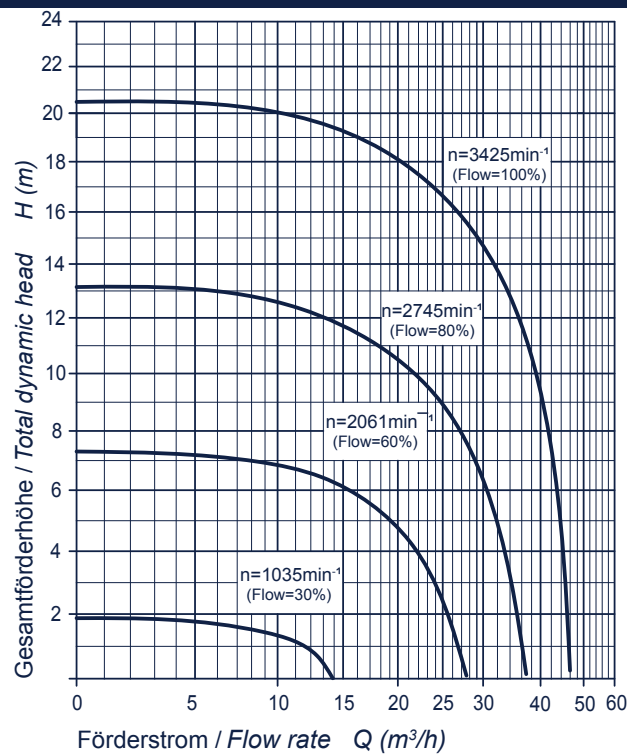

Maßzeichnung / Dimensioned drawing

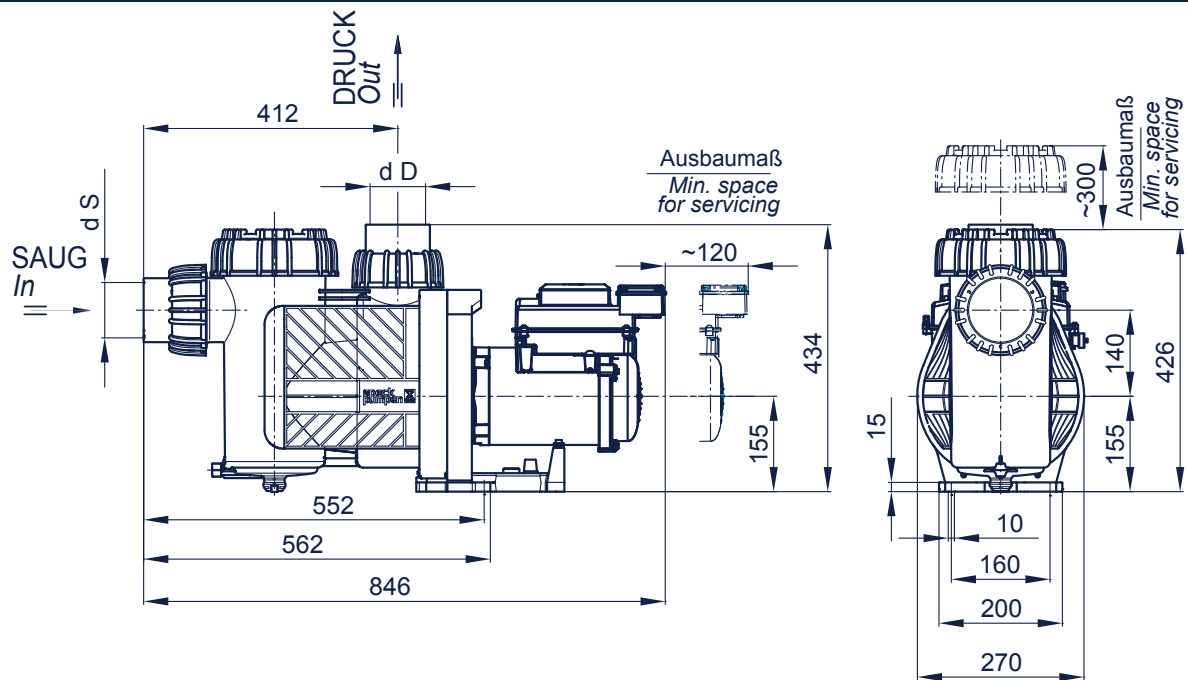

Technische Daten bei 50 Hz und 60 Hz Technical data at 50 Hz and 60 Hz

BADU®90/40 Eco MV-E

Saug / Druck, (mm) Inlet / outlet connection, (mm)		90/90
Empf. Saug- / Druckleitung, PVC-Rohr, d Rec. inlet / outlet pipe, PVC pipe, d		90/90
Leistungsaufnahme P_1 (kW) (min./max.) Power input P_1 (kW) (min./max.)	1~ 230 V	0,11/2,50
Leistungsabgabe P_2 (kW) (min./max.) ¹⁾ Power output P_2 (kW) (min./max.) ¹⁾	1~ 230 V	0,09/2,20
Nennstrom (A) (min./max.) Rated current (A) (min./max.)	1~ 230 V	0,6/12,0
Gewicht (kg) Weight (kg)	1~	36,0