

# BADU® 21-41

## Umwälzpumpen, normalsaugend Circulation pumps, non self-priming

### Kennlinien Characteristics

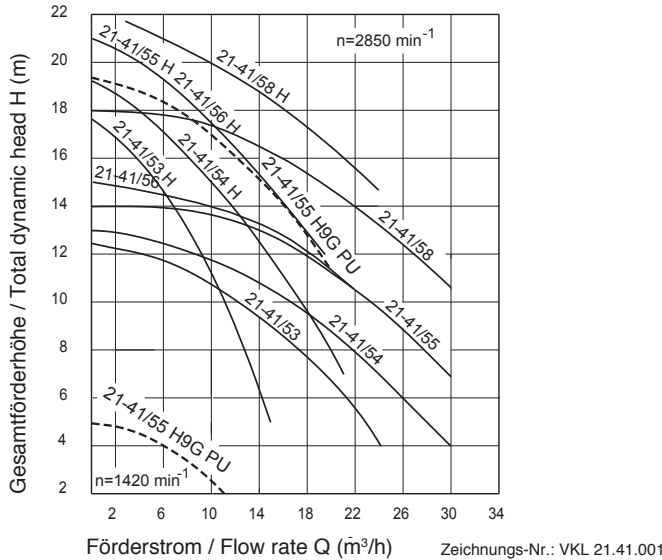

Druckstutzenstellungen  
(auf Saugstutzen gesehen)  
Möglichkeiten bei: 21-40/5. und 21-41/5.



0° (RO)



90° (UR)



180° (LU)



270° (OL)

Standard-Druckstutzenstellung: 0° (RO)

Standard discharge outlet position: 0° (RO)

Zeichnungs-Nr.: D 21.023-2

### Maßzeichnung Dimensioned drawing

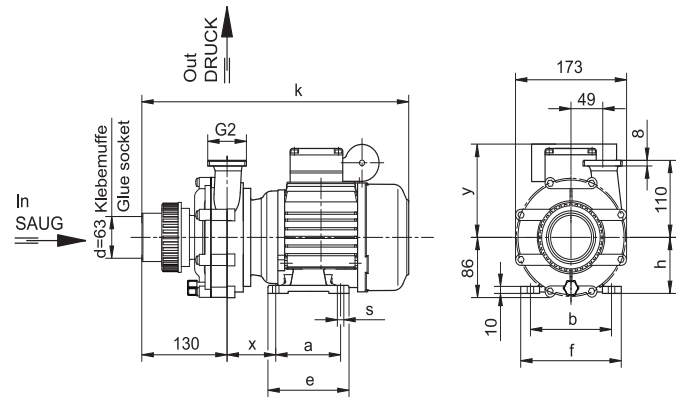

Zeichnungs-Nr.: VD 21.41.001

### Maßtabelle / Dimensioned table Maße in mm / Dimensions in mm

Typen / Types	a	b	e	f	h	s	x	y	k
21-41/53 G / H G	1~ 90	112	115	138	71	7,0	84	132	372
21-41/54 G / H G	1~ 90	112	115	138	71	7,0	84	132	372
21-41/55 G / H G	1~ 100	125	125	153	80	9,0	75	142	410
21-41/55H9 G PU	1~ 100	140	155	170	90	10,0	81	142	410
21-41/56 G / H G	3~ 100	125	125	153	80	9,0	75	128	410
21-41/58 G / H G	1~ 100	125	125	153	80	9,0	75	142	410
21-41/58 G / H G	3~ 100	125	125	153	80	9,0	75	128	435

Technische Daten bei 50 Hz Technical data at 50 Hz	BADU 21- BADU 21-	41/53 G 41/53H G	41/54 G 41/54H G	41/55 G 41/55H G	41/55H9 G PU	41/56 G 41/56H G	41/58 G 41/58H G
Saug Klebemuffe (d <sup>4</sup> ) / Druck (G) <sup>3</sup> Inlet connection glue socket (d <sup>4</sup> ) / outlet connection (G) <sup>3</sup>		63/2	63/2	63/2	63/2	63/2	63/2
Empf. Saug- / Druckleitung, PVC-Rohr, d <sup>4</sup> Rec. inlet / outlet pipe, PVC-pipe, d <sup>4</sup>		63/63	63/63	63/63	63/63	63/63	75/75
Leistungsaufnahme P <sub>1</sub> (kW) Power input P <sub>1</sub> (kW)	1~ 230 V	0,85	1,10	1,33	0,50/1,40	–	2,00
Leistungsabgabe P <sub>2</sub> (kW) <sup>1)</sup> Power output P <sub>2</sub> (kW) <sup>1)</sup>	1~ 230 V	0,55	0,75	1,00	0,22/1,00	–	1,50
Nennstrom (A) Rated current (A)	1~ 230 V	4,20	5,00	6,50	2,25/6,60	–	8,80
Leistungsaufnahme P <sub>1</sub> (kW) Power input P <sub>1</sub> (kW)	3~ Y/Δ 400/230 V	–	–	–	–	1,38	1,85
Leistungsabgabe P <sub>2</sub> (kW) <sup>1)</sup> Power output P <sub>2</sub> (kW) <sup>1)</sup>	3~ Y/Δ 400/230 V	–	–	–	–	1,10	1,50
Nennstrom (A) Rated current (A)	3~ Y/Δ 400/230 V	–	–	–	–	2,40/4,15	3,20/5,55
Gewicht (kg) Weight (kg)	1~	9,50	9,50	13,00	14,80	–	14,50
	3~	–	–	–	–	13,80	16,60

Schutzart des Motors IP 55  
Wärmeklasse F  
Drehzahl (min<sup>-1</sup>) ca. 1420\*\*)/2850  
Wassertemperatur (°C) max. 60  
Gehäuseinnendruck (bar) max. 2,5

Type of motor enclosure IP 55  
Class of insulation F  
Motor speed approx. (rpm) 1420\*\*)/2850  
Max. water temperature (°C) 60  
Max. casing pressure (bar) 2,5

<sup>1)</sup> Druckstutzen auch mit Schlauchtülle 40 oder Klebestutzen 40 lieferbar.

<sup>1)</sup> Discharge connection also available with hose adapter 40 or glue socket 40.

<sup>\*\*)</sup> Gilt nur für BADU 21-41/55H9 G PU.

<sup>\*\*)</sup> Only for the BADU 21-41/55H9 G PU.