

# BADU® 21-50 und / and BADU® 21-60

## Umwälzpumpen, normalsaugend Circulation pumps, non self-priming

### Kennlinien Characteristics

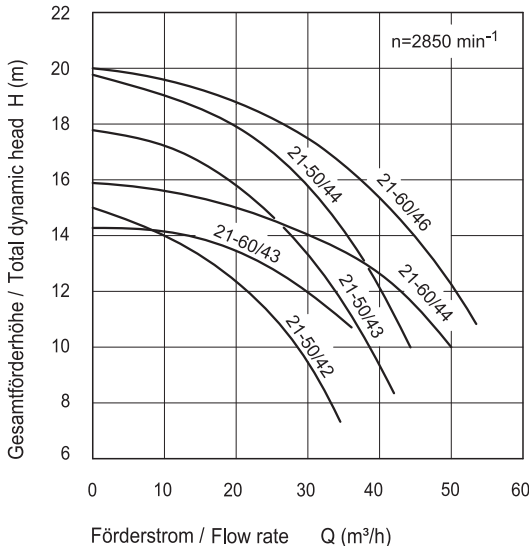

Zeichnungs-Nr.: VKL 21.011-4

### Maßzeichnung Dimensioned drawing

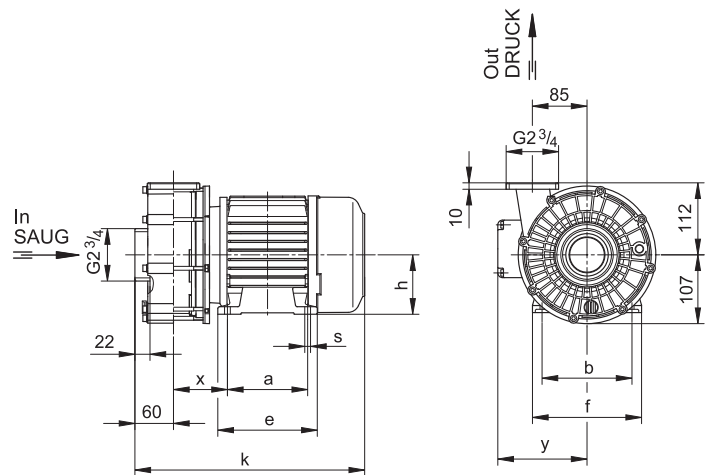

Zeichnungs-Nr.: VD 21.05.410-1

### Maßtabelle / Dimensioned table Maße in mm / Dimensions in mm

Pumpen / pumps Typ / Types	Motor / Motor 1~									Motor / Motor 3~								
	a	b	e	f	h	k	s	x	y	a	b	e	f	h	k	s	x	y
21-50/42 G	125	140	155	170	90	358	9	85	139	100	125	125	156	80	333	9	94	129**)
21-50/43 G	125	140	155	170	90	358	9	85	139	125	140	155	170	90	377	9	100	139
21-50/44 G	125	140	155	170	90	373	9	100	139	140	160	176	195	100	407	12	107	155
21-60/43 G	125	140	155	170	90	358	9	85	139	125	140	155	170	90	377	9	100	139
21-60/44 G	125	140	155	170	90	373	9	100	139	140	160	176	195	100	407	12	107	155
21-60/46 G	140	160	176	195	100	427	12	107	154	140	160	176	195	100	407	12	107	155

Technische Daten bei 50 Hz Technical data at 50 Hz	BADU 21-	50/42 G	50/43 G	50/44 G	60/43 G	60/44 G	60/46 G
Saug / Druck (G) <sup>3)</sup> Inlet / outlet connection (G) <sup>3)</sup>				Außengewinde 2 3/4 / 2 3/4 <sup>1)</sup> Male threads 2 3/4 / 2 3/4 <sup>1)</sup>			
Empf. Saug- / Druckleitung, PVC-Rohr, d <sup>4)</sup> Rec. inlet / outlet pipe, PVC-pipe, d <sup>4)</sup>		90/75	90/75	90/75	90/75	90/75	90/75
Leistungsaufnahme P <sub>1</sub> (kW) Power input P <sub>1</sub> (kW)	1~ 230 V	1,63	2,27	2,90	2,27	2,90	3,90
Leistungsabgabe P <sub>2</sub> (kW) <sup>1)</sup> Power output P <sub>2</sub> (kW) <sup>1)</sup>	1~ 230 V	1,10	1,60	2,20	1,60	2,20	3,00
Nennstrom (A) Rated current (A)	1~ 230 V	7,20	10,00	13,00	10,00	13,00	17,00
Leistungsaufnahme P <sub>1</sub> (kW) Power input P <sub>1</sub> (kW)	3~ Y/Δ 400/230 V	1,38	1,96	2,64	1,96	2,64	3,55
Leistungsabgabe P <sub>2</sub> (kW) <sup>1)</sup> Power output P <sub>2</sub> (kW) <sup>1)</sup>	3~ Y/Δ 400/230 V	1,10	1,60	2,20	1,60	2,20	3,00
Nennstrom (A) Rated current (A)	3~ Y/Δ 400/230 V	2,40/4,15	3,30/5,70	4,60/8,00	3,30/5,70	4,60/8,00	6,20/10,70
Gewicht (kg) Weight (kg)	1~ 3~	17,5 14,6	17,5 17,9	17,2 22,9	17,4 17,8	17,1 22,8	27,8 25,8

Schutzart des Motors IP 55  
Wärmeklasse F  
Drehzahl (min<sup>-1</sup>) ca. 2850  
Wassertemperatur (°C) max. 60  
Gehäuseinnendruck (bar) max. 2,5

<sup>1)</sup> Auch mit Außengewinden G 2 1/2 / G 2 oder Tüllenanschlüssen Ø 52/52 mm (BADU 21-50) bzw. Ø 72/52 mm (BADU 21-60) lieferbar.

<sup>\*\*)</sup> Bei BADU 21-50/42 G, 3~ Klemmkasten-Stellung oben.

Type of motor enclosure IP 55  
Class of insulation F  
Motor speed approx. 2850  
Max. water temperature (°C) 60  
Max. casing pressure (bar) 2,5

<sup>1)</sup> Also available with male threads G 2 1/2 / G 2 or socket connections of diameter 52/52 mm for BADU 21-50 and of diameter 72/52 mm for BADU 21-60.

<sup>\*\*)</sup> At BADU 21-50/42 G, 3~ terminal box position on the top.